

# Garden Tractor Clutch

P-1097-6  
819-0458

Troubleshooting and  
Installation Guide



## Contents

Terminology . . . . .	2
Troubleshooting Checklist . . . . .	3
Electrical Evaluation. . . . .	4
Airgap Adjustment . . . . .	6
Mounting . . . . .	11
Antirotation . . . . .	12
Antirotation Requirements . . . . .	13
Warranty . . . . .	Back Page

**⚠ WARNING** Failure to follow these instructions may result in product damage, equipment damage, and serious or fatal injury to personnel.

---

## Bearing Mounted Electric Clutch/Brake Assemblies and Operation

### Components

An electric clutch/brake or clutch consists of three primary components:

#### 1. Field Assembly

The clutch's "power" source contains the coil which generates magnetic force. Most common applications require a 12 volt DC coil, although other voltages are available.

#### 2. Rotor Assembly

Generally, the input of the clutch. Includes a keyed hub which mates with the keyway in the drive shaft. The rotor transmits torque from the drive shaft to the output, or armature assembly.

#### 3. Armature Assembly

Generally, the output of the clutch. Also contains the mechanical brake in a clutch/brake assembly. The armature transmits torque from the rotor to the driven load.

The sleeve is a secondary component. This sleeve serves as a spacer between the rotor and the field assembly, and is also a support for the field assembly bearing.

## Troubleshooting PTO Clutches and Clutch/Brakes

---

### A. Clutch Symptom: Clutch will not Engage

---

<b>Problem</b>	<b>Possible Causes</b>
Low voltage supply	<ul style="list-style-type: none"> <li>• Defective battery</li> <li>• Faulty charging system</li> <li>• Bad wiring or connectors</li> </ul>
Rotor/armature airgap too large	<ul style="list-style-type: none"> <li>• Rotor /armature wear, readjust airgap</li> </ul>
Zero voltage	<ul style="list-style-type: none"> <li>• Broken lead wire</li> <li>• Open clutch coil, check coil resistance</li> <li>• Faulty switch</li> <li>• Blown Fuse</li> </ul>

---

### B. Clutch Symptom: Clutch Slips

---

<b>Problem</b>	<b>Possible Causes</b>
Low voltage supply	<ul style="list-style-type: none"> <li>• Defective battery</li> <li>• Faulty charging system</li> <li>• Bad wiring or connectors</li> </ul>
Overloaded clutch	<ul style="list-style-type: none"> <li>• Improperly sized clutch</li> </ul>
Contaminated friction surfaces	<ul style="list-style-type: none"> <li>• Engine oil leak on clutch</li> </ul>
Clutch loose on shaft	<ul style="list-style-type: none"> <li>• Loose mounting bolt</li> <li>• Mounting bolt too long and bottoms in shaft before clamping clutch</li> <li>• Mounting washer too thin and deforms when bolt is tightened</li> </ul>
Clutch not mounted square	<ul style="list-style-type: none"> <li>• Mounting shoulder not square</li> <li>• Clutch integral key hitting end of keyway</li> <li>• Chamfer too small on spacer or ground drive pulley</li> </ul>
Broken rivet joints	<ul style="list-style-type: none"> <li>• Loose mounting, replace clutch</li> </ul>

---

### C. Clutch Symptom: Noisy Clutch

---

<b>Problem</b>	<b>Possible Causes</b>
Failed bearing	<ul style="list-style-type: none"> <li>• Loose mounting</li> <li>• Operating Temperature above 250° F</li> <li>• Bearing Preloaded Axially</li> </ul>
Adapter plate rattles against antiorotation pin	<ul style="list-style-type: none"> <li>• Some noise is normal: to reduce noise level, isolate antiorotation pin from frame with rubber</li> </ul>

## Instructions for Evaluating VX Series Clutches

Bearing Mounted Field Clutches (self-contained clutch/brake package)

**Clutch to be at room temperature - 70° F - for this check.**

### Step 1. Measure Clutch Coil resistance

1. Turn engine and PTO switch off.
2. Disconnect clutch wire connection.
3. Select meter to check ohms.
4. Connect meter lead wires to the wires in the clutch connector. (Figure 1)
5. If meter reads below 2.40 ohms or above 2.90 ohms, then the clutch has failed and needs to be replaced.

If the meter reads between 2.40 and 2.90 ohms, proceed to step 2.

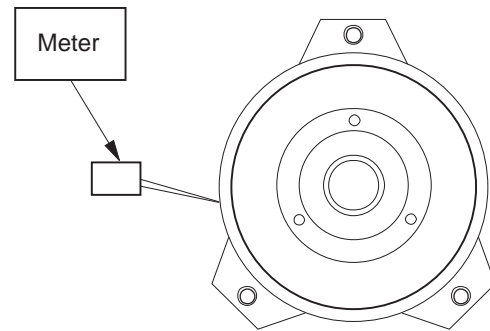

Figure 1

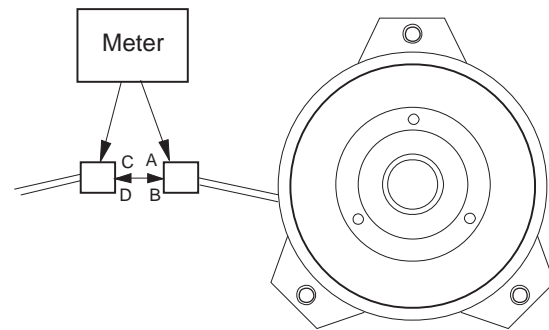

Figure 2

### Step 2. Measure Clutch Current Draw - 12 Volt System

1. Turn engine off.
2. Disconnect clutch wire connection.
3. Select meter to check amps (10 amp scale).
4. Connect one meter lead wire to one wire in clutch connector at A. (Figure 2)
5. Connect the other meter lead wire to the corresponding wire in the mating connector at C. (Figure 2)
6. Connect a short wire from D to B in both connectors. (Figure 2)
7. Turn PTO switch on.

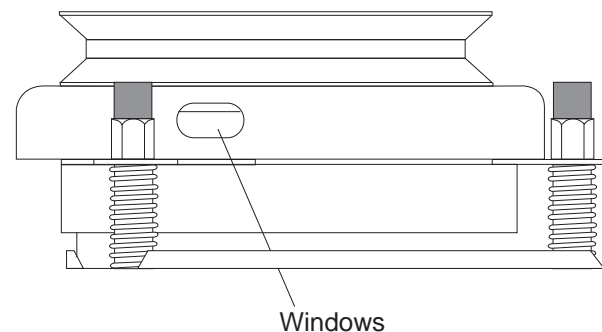

Figure 3

8. If meter reads below 4.0 amps, the problem would be in the electrical system leading to the clutch (battery, relay, switch, etc.).

If the meter reads 4.0 amps or above, proceed to Step 3.

### Step 3. Check Air Gap Setting

1. Turn engine and PTO switch off.
2. Locate the three "windows" or "notches" where the air gap is checked. (Figure 3)
3. With feeler gauge check gap at all three locations (minimum of two).
4. Factory air gap setting is .005" - .023".
5. If gap doesn't fall between .005" - .023" then reset using a .012" feeler gauge.

Changing the air gap is achieved by tightening and/or loosening the three nuts.

If you find after completing Steps 1, 2 and 3 that:

1. The resistance falls between 2.40 and 2.90.
2. The amp draw is 4.0 or above.
3. The air gap is between .005" and .023" or reset to .012". Then the electric clutch is within factory specifications and is not the source of the problem.

### Burnishing Procedure for Electric Clutch/Brake to be performed with mower deck attached.

1. Run at 50% throttle.
2. Engage and disengage the clutch 5 times. (10 seconds on/10 seconds off).
3. Increase to 75% throttle.
4. Engage and disengage the clutch 5 times. (10 seconds on/10 seconds off).

**Note:** All values taken at room temperature. Voltage at 12 VDC. As temperature increases, nresistance increases, and current decreases.

## Airgap Adjustment

### G. Procedure for Airgapping Bearing Mounted PTO Clutch/Brakes

Airgaps are preset at the factory and do NOT require initial adjustment.

#### Bench setting:

1. Remove clutch from tractor.
2. Orient the clutch so it is viewed from the field side.
3. Locate the three rivet joints in the armature assembly which fasten the leaf springs to the armature.

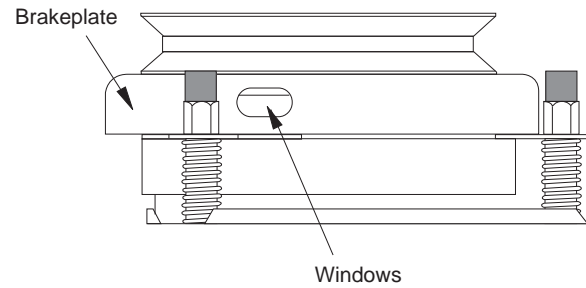

**Figure 17**  
 Location of Windows — Three Per Brakeplate

7. Insert a .012" feeler gauge through each window, being careful to position the feeler gauge between the rotor face and the armature face.

**Figure 16**

#### Positioning Rivet Joints for Airgap Adjustment

4. Rotate the pulley until these three rivet joints are located midway along the edge of the triangular adapter, or halfway between each stud. This prevents measuring the airgap over a rivet joint.
5. Do not disturb the orientation of the armature assembly with respect to the field.
6. Locate the three windows in the brakeplate, one at each stud.

**Figure 18**  
 Setting the Airgap

8. With all three feeler gauges in place, begin to alternately tighten each nut an equal amount.
9. Tighten each nut until the feeler gauges begin to feel snug. Each gauge should require an equal amount of force for insertion and extraction.
10. Remove the feeler gauges. Turn the rotor assembly to check for rotor/armature drag. The rotor should turn freely.

11. Due to dimensional variations, the airgap between the rotor and armature may vary on a clutch from .023/.005", even though the gap at the three windows was set at .012". This is an acceptable condition.
12. Using feeler gauges, check the airgap through the three windows. If the airgap does not fall between .023/.005", repeat the above procedure. Remember: Never check the airgap directly over a rivet joint.
14. As an alternative to mounting directly to the crankshaft in setting the gap, an assembly fixture consisting of a stub shaft with a shoulder can also be used. This stub shaft should duplicate the crankshaft dimensions. Secure the clutch to this shaft as noted above in Step 13.

**Option 1: Setting on the engine crankshaft.**

13. To help set the airgap, mount the unair-gapped unit directly to the engine crankshaft, securing it to the shaft with the appropriate bolt and washer with a minimum thickness of .250". When going from an unclamped state to a clamped state, the clearance between the rotor and armature is reduced about .002". A .012" feeler gauge should still be used in the clamped state. If a 3/8" diameter bolt is used, tightening torque on the bolt should be 340-45 lb.ft. Grade 8 bolt. If a 7/16" diameter bolt is used, tightening torque on this bolt should be 50-55 lb.ft. Grade 5 or 8 bolt.

**Note:** Care must be exercised when setting the airgap with the clutch secured to the shaft, as it is difficult to detect rotor/armature drag when the engine is running.

## Airgap Adjustment

### Locating the Rivet Joints

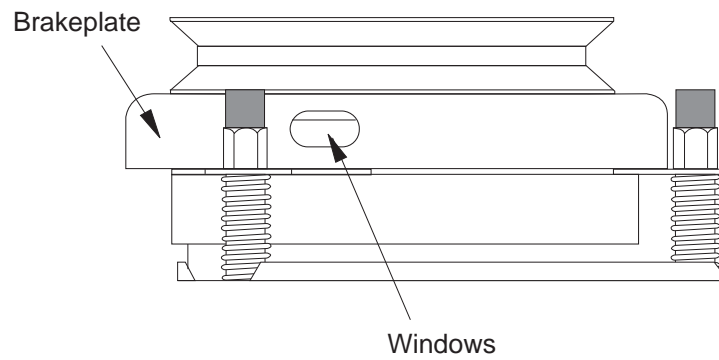

### Locating the Windows

### Inserting the Feeler Gauges



## Mounting the Clutch/Brake

### NOTE:

1. Proper bolt torque is critical.
2. Always bottom the clutch against a flat surface; never against a radius.

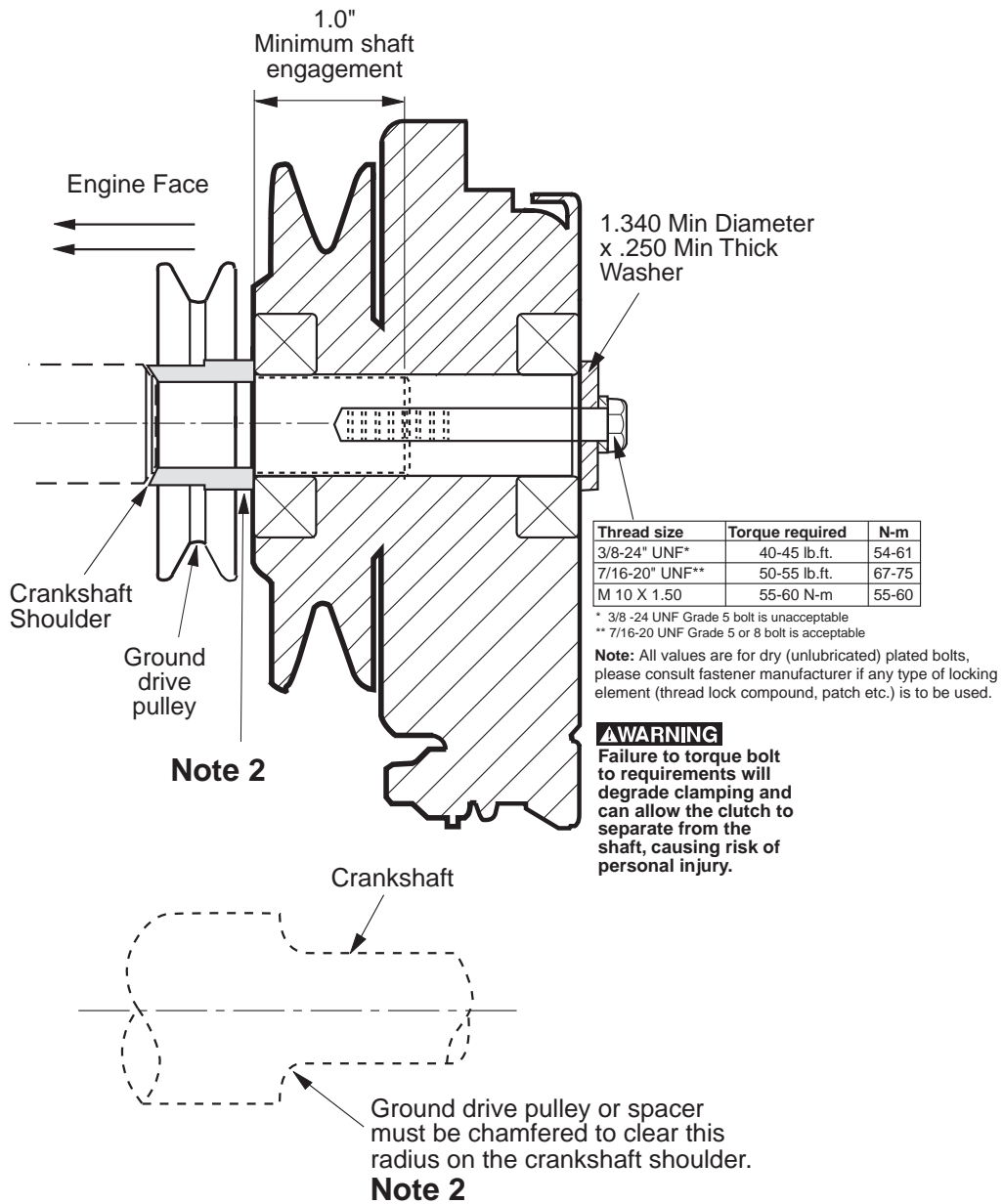

## Antirotation Brackets Suggested Configurations

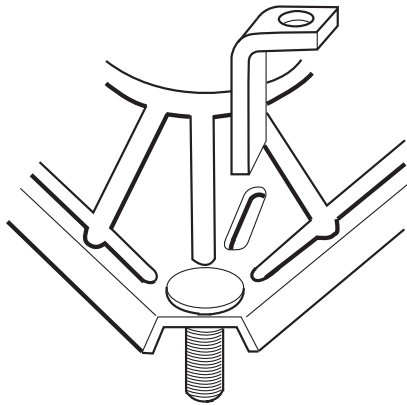

(Figure 11)  
 1/4" x 5/8" Bent Flat  
 Steel Field Restraint

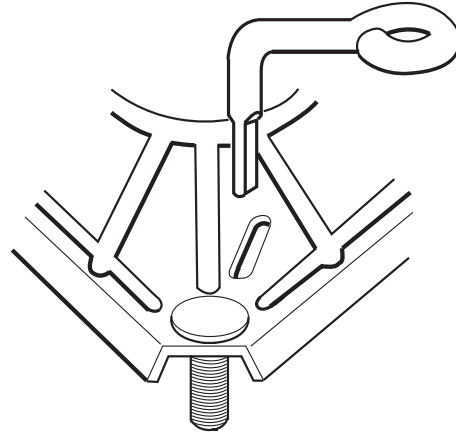

(Figure 12)  
 5/16" Diameter Bent Steel  
 Rod Field Restraint

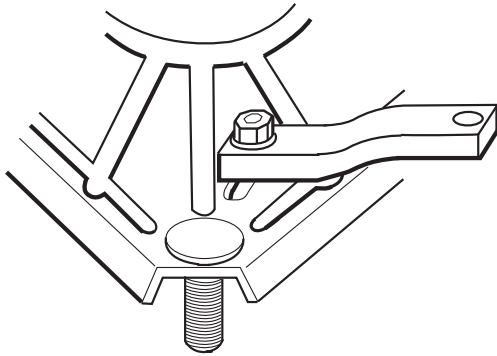

(Figure 13)  
 1/4" x 3/4" Rubber Stop  
 Field Restraint

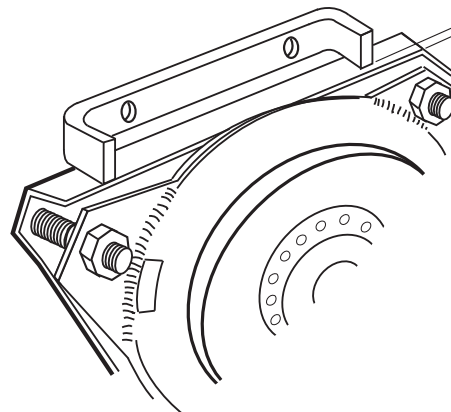

(Figure 14)  
 1/8" x 3/4" Bent Flat  
 Steel Restraint

Wheel clearance  
 between brake/  
 clutch and steel  
 restraint 1/16"  
 required here.

## Antirotation Requirements

Do Not Restict the Field Assembly

Some movement is required

to prevent field bearing failure.





**INDUSTRIAL MAGZA**  
DIST. AUTORIZADO

MEX (55) 53 63 23 31 MTY (81) 83 54 10 18  
QRO (442) 1 95 72 60 [ventas@industrialmagza.com](mailto:ventas@industrialmagza.com)



Warner Electric LLC  
449 Gardner Street • South Beloit, IL 61080  
815-389-3771 • Fax: 815-389-2582  
[www.warnerelectric.com](http://www.warnerelectric.com)